

## Shrink Disc MAV 2008 standard duty

rev. 1

### Features:

- shaft to hollow shaft connection
- 3-part design
- not self-locking
- screws DIN 931/933 grade 10.9
- shaft / hub surface finish  $Ra < 3,2 \mu m$
- hollow shaft outer diameter tolerance: h8
- hub bore / shaft fitting tolerance:

shaft size $ds$		ISO tolerances	max clearance mm
from	to		
6	10	H6 - j6	0,011
11	18		0,014
19	30		0,017
31	50	H6 - h6	0,032
51	80	H6 - g6	0,048
81	120	H7 - g6	0,069
121	180		0,079
181	250		0,090
251	315		0,101
316	400		0,111
401	500		0,123

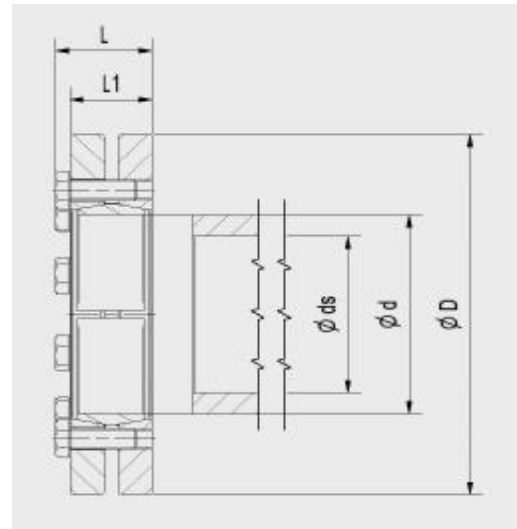

Ma: screw tightening torque  
 Mt: max. transmissible torque (Fax=0 kN)  
 Fax: max. transmissible axial load (Mt=0Nm)  
 Ps: contact pressure on shaft  
 Ph: contact pressure on hub OD

### Example of order: MAV2008 – 50 x 90

Dimensions					Screws		Performance				Weight		
$ds$ mm	$d$ mm	$x$ mm	$D$ mm	$L$ mm	$L1$ mm	n.	size	$Ma$ Nm	$Mt$ Nm	$Fax$ kN	$Ps$ N/mm <sup>2</sup>	$Ph$ N/mm <sup>2</sup>	kg
10									36	7	154	335	
11	14	x	38	18,5	15	3	M 5	4	54	10	191	335	0,10
12									82	14	243	335	
12	16	x	41	20,5	17	3	M 5	4	38	6	93	244	
13									65	10	136	244	0,10
14									97	14	175	244	
14	18	x	44	20,5	17	4	M 5	4	96	14	172	289	
15									130	17	205	289	0,14
16									170	21	235	289	
15	20	x	46	20,5	17	5	M 5	4	130	17	205	325	
16									170	21	232	325	0,15
17									210	25	258	325	
19	24	x	50	21,5	18	6	M 5	4	220	24	189	279	
20									280	28	209	279	0,19
21									330	32	228	279	
24	30	x	60	23,5	20	7	M 5	4	350	29	159	228	
25									400	32	172	228	0,29
26									470	36	184	228	
28	36	x	72	26,0	22	5	M 6	12	770	55	232	297	
30									960	64	250	297	0,47
31									980	63	240	297	
34	44	x	80	28,0	24	7	M 6	12	1.200	72	225	306	
35									1.400	77	235	306	0,6
36									1.500	83	244	306	
38	50	x	90	31,0	27	8	M 6	12	1.500	80	204	280	
40									1.800	91	219	280	0,8
42									2.100	101	232	280	

## Shrink Disc MAV 2008 standard duty

rev. 1

### Features:

- shaft to hollow shaft connection
- 3-part design
- not self-locking
- screws DIN 931/933 grade 10.9
- shaft / hub surface finish  $R_a < 3,2 \mu\text{m}$
- hollow shaft outer diameter tolerance: h8
- hub bore / shaft fitting tolerance:

shaft size $d_s$		ISO tolerances	max clearance mm
from	to		
6	10	H6 - j6	0,011
11	18		0,014
19	30		0,017
31	50	H6 - h6	0,032
51	80	H6 - g6	0,048
81	120	H7 - g6	0,069
121	180		0,079
181	250		0,090
251	315		0,101
316	400		0,111
401	500		0,123

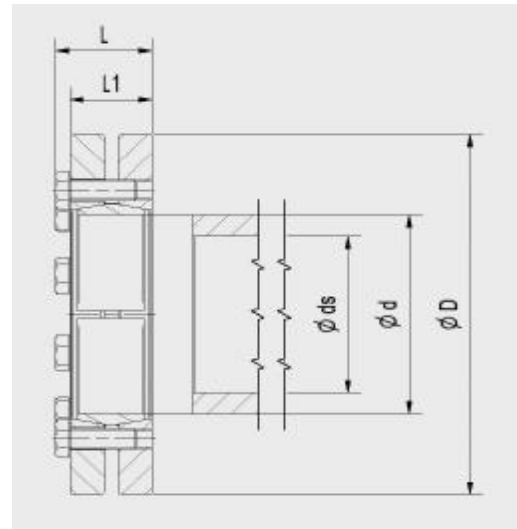

Ma: screw tightening torque  
 Mt: max. transmissible torque (Fax=0 kN)  
 Fax: max. transmissible axial load (Mt=0Nm)  
 Ps: contact pressure on shaft  
 Ph: contact pressure on hub OD

### Example of order: MAV2008 – 50 x 90

Dimensions					Screws			Performance				Weight
$d_s$ mm	d x D mm mm	L mm	L1 mm	n.	size	Ma Nm	Mt Nm	Fax kN	Ps N/mm <sup>2</sup>	Ph N/mm <sup>2</sup>	kg	
42	55 x 100	33,0	29	8	M 6	12	1.700	80	176	243	1,1	
45							2.100	94	193	243		
48							2.600	110	210	243		
48	62 x 110	33,0	29	10	M 6	12	2.700	110	213	270	1,3	
50							3.000	120	222	270		
52							3.200	120	218	270		
50	68 x 115	33,0	29	10	M 6	12	2.500	100	184	246	1,3	
55							3.100	110	188	246		
60							4.100	140	212	246		
55	75 x 138	36,3	31	7	M 8	30	3.500	130	199	276	2,2	
60							4.700	160	221	276		
65							6.000	180	241	276		
60	80 x 145	36,3	31	7	M 8	30	4.100	140	192	259	2,4	
65							5.200	160	211	259		
70							6.600	190	228	259		
60	85 x 155	43,3	38	10	M 8	30	5.400	180	213	290	3,4	
65							6.900	210	231	290		
70							8.600	250	248	290		
65	90 x 155	43,3	38	10	M 8	30	6.200	190	206	274	3,3	
70							7.700	220	222	274		
75							9.400	250	236	274		
65	95 x 170	48,3	43	12	M 8	30	6.800	210	200	274	4,6	
70							8.400	240	215	274		
75							10.300	270	228	274		
70	100 x 170	48,3	43	12	M 8	30	7.600	220	194	261	4,4	
75							9.300	250	207	261		
80							11.300	280	220	261		

## Shrink Disc MAV 2008 standard duty

rev. 1

### Features:

- shaft to hollow shaft connection
- 3-part design
- not self-locking
- screws DIN 931/933 grade 10.9
- shaft / hub surface finish  $Ra < 3,2 \mu m$
- hollow shaft outer diameter tolerance: h8
- hub bore / shaft fitting tolerance:

shaft size $ds$		ISO tolerances	max clearance mm
from	to		
6	10	H6 - j6	0,011
11	18		0,014
19	30		0,017
31	50	H6 - h6	0,032
51	80	H6 - g6	0,048
81	120	H7 - g6	0,069
121	180		0,079
181	250		0,090
251	315		0,101
316	400		0,111
401	500		0,123

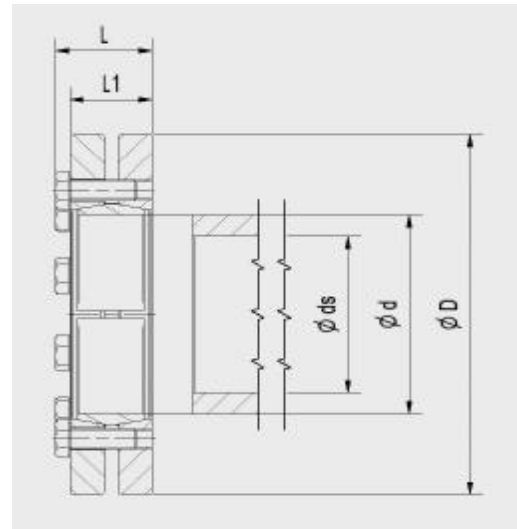

Ma: screw tightening torque  
 Mt: max. transmissible torque (Fax=0 kN)  
 Fax: max. transmissible axial load (Mt=0Nm)  
 Ps: contact pressure on shaft  
 Ph: contact pressure on hub OD

### Example of order: MAV2008 – 50 x 90

Dimensions					Screws		Performance				Weight
$ds$ mm	$d \times D$ mm	$L$ mm	$L1$ mm	n.	size	$Ma$ Nm	$Mt$ Nm	$Fax$ kN	$Ps$ N/mm <sup>2</sup>	$Ph$ N/mm <sup>2</sup>	kg
70	105 x 185	55,4	49	9	M 10	59	8.100	230	180	253	6,2
75							10.000	270	193	253	
80							12.100	300	205	253	
75	110 x 185	55,4	49	9	M 10	59	9.100	240	176	242	5,9
80							11.000	280	188	242	
85							12.200	290	183	242	
80	115 x 200	56,4	50	10	M 10	59	11.500	290	191	250	7,2
85							12.600	300	185	250	
90							15.100	340	198	250	
85	120 x 200	56,4	50	10	M 10	59	11.400	270	168	240	7,0
90							13.800	310	180	240	
95							16.300	340	192	240	
85	125 x 215	59,4	53	12	M 10	59	13.300	310	186	263	8,7
90							15.800	350	198	263	
95							18.600	390	209	263	
90	130 x 215	59,4	53	12	M 10	59	14.600	320	182	253	8,4
95							17.200	360	193	253	
100							20.100	400	203	253	
95	140 x 230	65,5	58	10	M 12	100	18.600	390	190	259	10
100							21.600	430	199	259	
105							24.900	470	208	259	
105	155 x 263	69,5	62	12	M 12	100	25.400	480	195	259	15
110							29.000	530	203	259	
115							32.800	570	211	259	
115	165 x 290	78,0	68	8	M 16	250	38.900	680	223	278	21
120							43.600	730	230	278	
125							47.600	760	231	278	

## Shrink Disc MAV 2008 standard duty

rev. 1

### Features:

- shaft to hollow shaft connection
- 3-part design
- not self-locking
- screws DIN 931/933 grade 10.9
- shaft / hub surface finish  $Ra < 3,2 \mu m$
- hollow shaft outer diameter tolerance: h8
- hub bore / shaft fitting tolerance:

shaft size $ds$		ISO tolerances	max clearance mm
from	to		
6	10	H6 - j6	0,011
11	18		0,014
19	30		0,017
31	50	H6 - h6	0,032
51	80	H6 - g6	0,048
81	120	H7 - g6	0,069
121	180		0,079
181	250		0,090
251	315		0,101
316	400		0,111
401	500		0,123

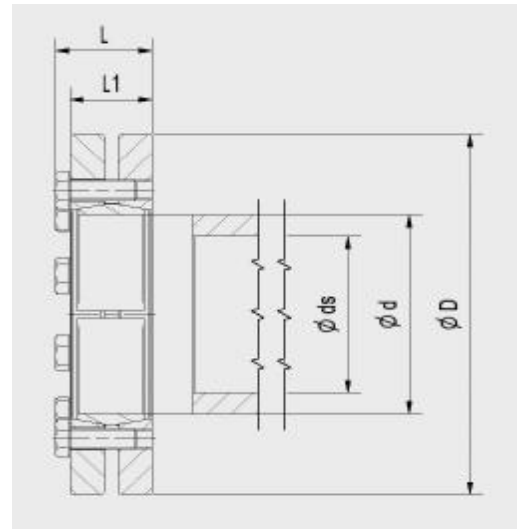

Ma: screw tightening torque  
 Mt: max. transmissible torque (Fax=0 kN)  
 Fax: max. transmissible axial load (Mt=0Nm)  
 Ps: contact pressure on shaft  
 Ph: contact pressure on hub OD

### Example of order: MAV2008 – 50 x 90

Dimensions					Screws		Performance				Weight
$ds$ mm	$d \times D$ mm	$L$ mm	$L1$ mm	n.	size Ma Nm	Mt Nm	Fax kN	Ps N/mm <sup>2</sup>	Ph N/mm <sup>2</sup>	kg	
125	175 x 300	78,0	68	8	M 16 250	42.900	690	208	262	21	
130						47.800	740	215	262		
135						53.100	790	221	262		
135	185 x 330	95,0	85	10	M 16 250	60.000	890	197	244	34	
140						66.400	950	202	244		
145						73.100	1.000	208	244		
140	195 x 350	95,0	85	12	M 16 250	75.600	1.100	231	278	38	
150						90.600	1.200	241	278		
155						98.700	1.300	245	278		
150	200 x 350	95,0	85	12	M 16 250	87.000	1.200	231	271	37	
155						94.800	1.200	236	271		
160						103.000	1.300	240	271		
160	220 x 370	114,0	104	15	M 16 250	110.000	1.400	208	249	50	
165						120.000	1.500	212	249		
170						129.000	1.500	216	249		
170	240 x 405	120,5	108	12	M 20 490	146.000	1.700	233	273	63	
180						168.000	1.900	239	273		
190						190.000	2.000	243	273		
180	250 x 430	131,5	119	14	M 20 490	186.000	2.100	236	273	82	
190						209.000	2.200	239	273		
200						238.000	2.400	245	273		
190	260 x 430	131,5	119	14	M 20 490	197.000	2.100	225	262	78	
200						224.000	2.200	231	262		
210						254.000	2.400	237	262		
210	280 x 460	144,5	132	16	M 20 490	260.000	2.500	220	252	97	
220						292.000	2.700	225	252		
230						327.000	2.800	230	252		

## Shrink Disc MAV 2008 standard duty

rev. 1

### Features:

- shaft to hollow shaft connection
- 3-part design
- not self-locking
- screws DIN 931/933 grade 10.9
- shaft / hub surface finish  $Ra < 3,2 \mu m$
- hollow shaft outer diameter tolerance: h8
- hub bore / shaft fitting tolerance:

shaft size $ds$		ISO tolerances	max clearance mm
from	to		
6	10	H6 - j6	0,011
11	18		0,014
19	30		0,017
31	50	H6 - h6	0,032
51	80	H6 - g6	0,048
81	120	H7 - g6	0,069
121	180		0,079
181	250		0,090
251	315		0,101
316	400		0,111
401	500		0,123

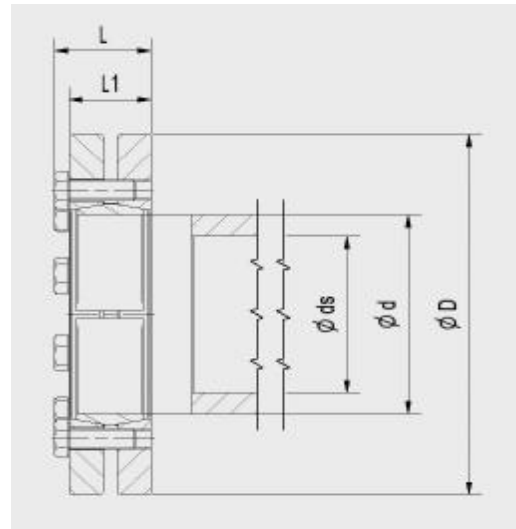

Ma: screw tightening torque  
 Mt: max. transmissible torque (Fax=0 kN)  
 Fax: max. transmissible axial load (Mt=0Nm)  
 Ps: contact pressure on shaft  
 Ph: contact pressure on hub OD

### Example of order: MAV2008 – 50 x 90

Dimensions					Screws		Performance				Weight		
$ds$ mm	$d$ mm	$x$ mm	$D$ mm	$L$ mm	$L1$ mm	n.	size	$Ma$ Nm	$Mt$ Nm	$Fax$ kN	$Ps$ N/mm <sup>2</sup>	$Ph$ N/mm <sup>2</sup>	kg
230	300	x	485	152,5	140	18	M 20	490	334.000	2.900	219	247	113
240									371.000	3.100	224	247	
250									410.000	3.300	228	247	
240	320	x	520	152,5	140	20	M 20	490	380.000	3.200	229	257	131
250									419.000	3.400	233	257	
260									457.000	3.500	235	257	
250	340	x	570	168,5	156	24	M 20	490	465.000	3.700	232	261	186
260									506.000	3.900	233	261	
270									555.000	4.100	237	261	
260	350	x	580	172,5	160	24	M 20	490	483.000	3.700	217	246	193
270									530.000	3.900	220	246	
280									580.000	4.100	224	246	
280	360	x	590	172,5	160	24	M 20	490	556.000	4.000	215	239	197
290									606.000	4.200	219	239	
295									632.000	4.300	220	239	
290	380	x	645	179,0	164	20	M 24	840	682.000	4.700	239	263	255
300									739.000	4.900	242	263	
310									799.000	5.200	245	263	
310	390	x	660	179,0	164	21	M 24	840	813.000	5.200	249	269	266
315									844.000	5.400	251	269	
320									871.000	5.400	251	269	
315	400	x	680	199,0	184	21	M 24	840	806.000	5.100	210	231	314
320									831.000	5.200	210	231	
330									896.000	5.400	213	231	
330	420	x	690	199,0	184	24	M 24	840	967.000	5.900	230	251	311
340									1.040.000	6.100	232	251	
350									1.110.000	6.400	235	251	

## Shrink Disc MAV 2008 standard duty

rev. 1

### Features:

- shaft to hollow shaft connection
- 3-part design
- not self-locking
- screws DIN 931/933 grade 10.9
- shaft / hub surface finish  $Ra < 3,2 \mu m$
- hollow shaft outer diameter tolerance: h8
- hub bore / shaft fitting tolerance:

shaft size $ds$		ISO tolerances	max clearance mm
from	to		
6	10	H6 - j6	0,011
11	18		0,014
19	30		0,017
31	50	H6 - h6	0,032
51	80	H6 - g6	0,048
81	120	H7 - g6	0,069
121	180		0,079
181	250		0,090
251	315		0,101
316	400		0,111
401	500		0,123

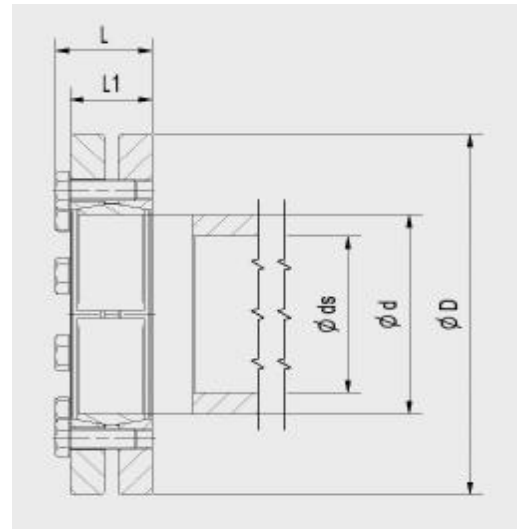

Ma: screw tightening torque  
 Mt: max. transmissible torque (Fax=0 kN)  
 Fax: max. transmissible axial load (Mt=0Nm)  
 Ps: contact pressure on shaft  
 Ph: contact pressure on hub OD

### Example of order: MAV2008 – 50 x 90

Dimensions					Screws		Performance				Weight
$ds$ mm	$d \times D$ mm	$L$ mm	$L1$ mm	n.	size	$Ma$ Nm	$Mt$ Nm	$Fax$ kN	$Ps$ N/mm <sup>2</sup>	$Ph$ N/mm <sup>2</sup>	kg
340	440 x 750	207,0	192	24	M 24	840	970.000	5.700	207	229	392
350							1.040.000	5.900	209	229	
360							1.110.000	6.200	212	229	
360	460 x 770	207,0	192	24	M 24	840	1.040.000	5.800	199	219	405
370							1.120.000	6.000	201	219	
380							1.190.000	6.300	203	219	
380	480 x 800	228,0	213	30	M 24	840	1.420.000	7.500	221	240	485
390							1.510.000	7.700	224	240	
400							1.600.000	8.000	225	240	
400	500 x 850	230,0	213	24	M 27	1250	1.620.000	8.100	228	245	560
410							1.700.000	8.300	229	245	
420							1.800.000	8.600	231	245	

Information subject to change without prior notification. © MAV S.p.A.